

STOROrail SPECIAL

Blinds in train driver's cabin, made to measure

- Guide by coated lateral rod on each side
- Rods bent according to the shape of the front- and side screen
- Height of blinds infinitely adjustable
- No parts which wear, hence undisturbed function
- Fabrics of blinds under permanent tension
- Blinds with or without case
- Trevira CS black-out fabrics
- Fire resistance according to DIN 5510 S4 SR2 ST2
- Installation at any time, straight forward fitting by mechanics
- Care: carefree service and maintenance
- Guaranteed three full years

Options

- Horizontal fitting with open-shut position
- Dazzle-free or black-out fabrics
- Various colours and fabrics available



TEXAT decor engineering Ltd.
Switzerland
www.tde.ch/en

Represented in Australia by Unique Engineering (Aust) Pty Ltd.
www.uniqueengineering.com.au



STOROrail SPECIAL
Blinds for trains and trams

- blinds for screens
- side windows
- screens of partition walls

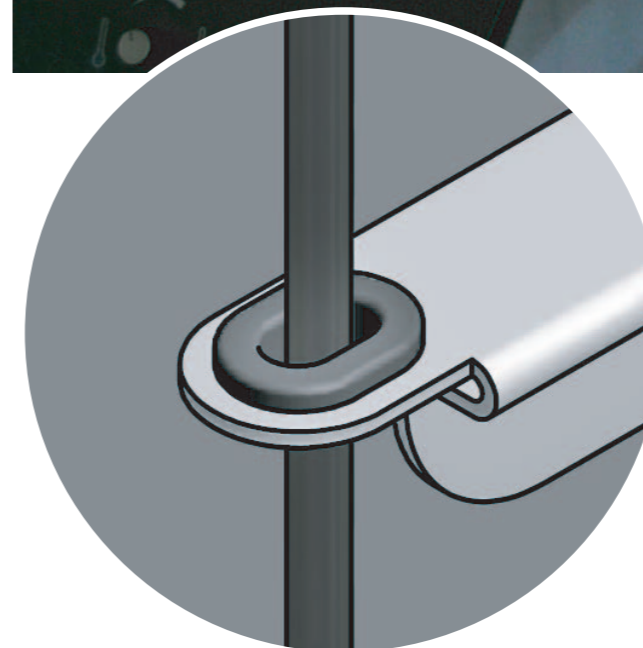

Unique Engineering Australia
Factory 3, 6 Deblin Drive, Narre Warren Vic 3805
PO Box 2251, Fountain Gate Vic 3805
Tel: (03) 9705 9522 Fax: (03) 9705 9471

STORO
rail SPECIAL